

INSULATED CHILLTEMP® REFRIGERATED CABINET MODEL R-171-SUA-20

FEATURES AND BENEFITS:

- Fully insulated double capacity mobile ChillTemp® refrigerated cabinet for holding food and beverages at serving temperature.
- Forced air system provides even distribution of cold air; cabinet maintains temperatures from 33°F (.5° C) to 40°F (4.5° C). Automatically defrosts.
- 1/3 horsepower compressor with automatic overload reset. R134a refrigerant for environmental compatibility.
- Stainless steel construction throughout for ease of cleaning. One piece extended base protects cabinet body.
- Push/pull handles on both sides prevent damage to walls; allows easy maneuvering.
- Self-closing insulated doors prevent temperature loss. Magnetic door gaskets for proper seal.
- Safety-conscious anti-microbial handles protect against spreading germs.
- Full length extruded door handles for "easy open"; positive catch (available in USA only) secures door during transport.
- Generous 39-cubic foot interior.
- Twenty sets of chrome plated wire universal angles accommodate a large variety of pan sizes on adjustable 1-1/2" centers.
- Heavy duty 6" casters, two rigid and two swivel with brakes. Provides mobility when fully loaded.
- One piece welded base with perimeter bumper provides solid foundation to support heavy loads.



R-171-SUA-20

SANITATION
NSF/ANSI 4

C US

ACCESSORIES and OPTIONS (Available at extra cost):

- Extra Universal Angles
 - Drop Down Pull Handle
 - Menu Card Holder
 - Polyurethane Casters
 - Magnetic Door Latch (USA only)
 - 240 Volt Service
 - Digital Thermometer
 - Interior for (56) 18" x 26" pans
- See page K-2 for accessory details.

R-171-SUA-20

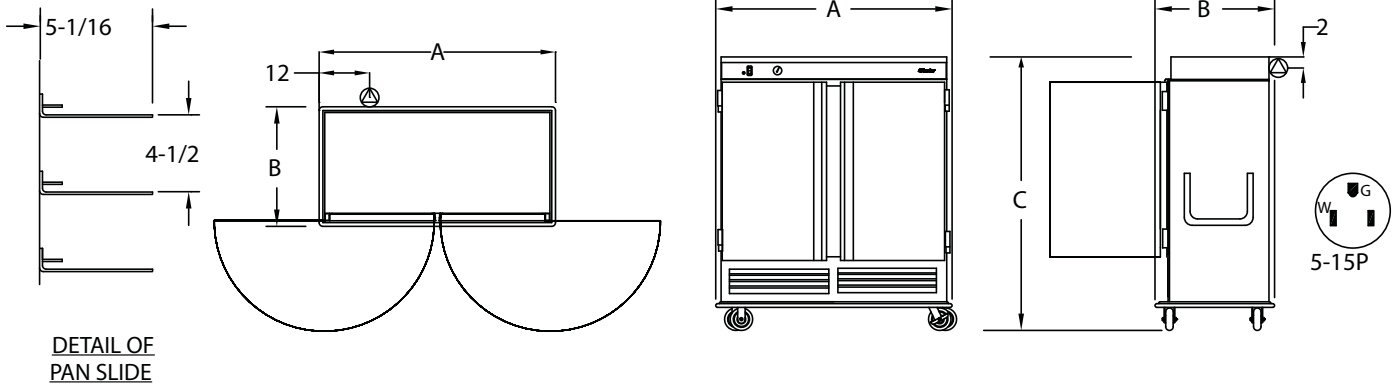

DETAIL OF
PAN SLIDE

CRES COR MODEL NO.	PAN			DIM "A"	DIM "B"	DIM "C"	INSIDE DIMENSIONS				WEIGHT ACT.
	CAP/ ANGLES	SIZE		WIDTH	DEPTH	HEIGHT	WIDTH	DEPTH	HEIGHT		
R-171-SUA-20	20 SETS	SEE NOTE BELOW	IN	62	35-1/2	74-3/4	22	27-1/2	46-3/4	LBS	580
			MM	1575	905	1900	560	700	1190	KG	263

NOTES: 1. Pan sizes 22" x 20" (560 x 510) Roast & Bake Pans, 10" x 20" (255 x 510) Roast & Bake Pans, 18" x 26" (460 x 660) Bun Pans, 14" x 18" (355 x 460) Service Trays, 12" x 20" (305 x 510) Steam Table Pans.
Refer to Pan Size Chart at end of section.

2. When ordering bumpers, add 2" to overall dimensions.

ALL CONSTRUCTION IS RIVETED, WELDED AND FINISHED.

CABINET:

- Body: 22 ga. stainless steel.
- Reinforcement: Internal framework of 16 ga. stainless steel.
- Insulation: Fiberglass, thermal conductivity (K factor) is .23 at 75°F. 1-1/2" in doors, base, top; 2" in sidewalls.
- Push/pull handles (2).
- Interior coved corners.

BASE:

- One piece construction, .125 aluminum.
- Casters: 6" dia., modulus tires, 2" wide, load cap. 450 lbs. each, temp. range -45°/+180°F. Zerk fittings. Two rigid and two swivel casters with brakes.
- Perimeter bumper: 1 x 1 gray non-marking rubber.

DOORS:

- Formed 22 ga. stainless steel.
- Extruded handles.
- Transport latches.
- Hinges: Heavy duty chrome plated steel.
- Gaskets: Perimeter type, magnetic Santoprene.
- Pan stops: Embossed.

PAN SLIDES:

- Wire angles (.306 dia.), nickel chrome plated steel, mounted on lift-off posts.
- Spaced on 4-1/2" centers; adjustable on 1-1/2" centers.

ELECTRICAL COMPONENTS:

- Thermostat: Pre-set to 38° F (3.3° C).
- Pilot light.
- Switch.
- Power cord: Permanent, 10 ft., 14/3 ga. with molded plug.
- Compressor: 1/3 h.p.
- Condensate evaporator: Electrical.
- R134a refrigerant.
- Vent fan

POWER REQUIREMENTS:

- 120 Volts, 60 Hz., single phase, 15 Amp. service.

SHORT FORM SPECIFICATIONS

Cres Cor Refrigerated Cabinet Model R-171-SUA-20. Cabinet 22 ga. stainless steel; stainless steel internal frame. (20) sets of wire universal angles for multiple pan sizes, adjustable spacing every 1-1/2". Doors, 22 ga. stainless steel. Fiberglass insulation in sides 2"; doors, base, top 1-1/2". Interior coved corners. 1/3 h.p. compressor, 120 Volts. One piece insulated base, .125 aluminum. 6" casters, (2) rigid and (2) swivel with brakes, Zerk fittings. Load capacity 450 lbs. each. Perimeter bumper. 2 year parts warranty. Provide the following accessories: _____ . CSA-US/C, CSA to NSF7 listed.



5925 Heisley Road • Mentor, OH 44060-1833
Phone: 877/CRESCOR • Fax: 440/350-7267
www.crescor.com

© Crescent Metal Products, Inc. 2010 All rights reserved.

In line with its policy to continually improve its products, CRES COR reserves the right to change materials and specifications without notice.

Litho in U.S.A.