

Product Name	ThermaCube™ Delivery System Induction Charger	Quantity		Item #	
--------------	---	----------	--	--------	--



Note: For use with CookTek® TCS System specific heated delivery bags and pellets only.

Bag sold separately. Standard bag is black.



Standard Features

- Initial charge in four minutes or less
- Recharges in 60 seconds (average)
- No-leak, solid-to-solid phase change material extends heating time
- Lightweight pellet and bag
- Manufactured and designed for easy installation and use - no cord to the bag, no heating element maintenance, and no extra labor steps
- Heat energy is generated and contained in a pellet located in the delivery bag. The charger surface does not get hot.
- Charger performs self-diagnostic features and alerts the user in the event of an error
- User-friendly control panel and LED lighted displays are easy to understand and simple to operate
- Charger manufactured and designed to handle exposure to flour, dust, oil, grease, and various other food substances found in food establishments
- Manufactured and designed to operate on a standard countertop or “dropped-in” to a custom shelving unit
- Requires 100-120VAC/15A dedicated single phase outlet
- Three year limited warranty on charger only
- Made in the USA*

Specifications

Shall be a CookTek® induction thermal delivery system, model _____ with a total kW rating of _____.

Unit shall be fabricated with a powder-coated steel housing, polycarbonate locator tray and membrane control panel.

Unit shall be a high power induction heating system, intended for the rapid thermal charging of a special heat retaining pellet, correctly installed in a CookTek® approved insulated bag.

Unit shall operate on _____ power with integral _____ cord and plug (supplied).

NOTE: ThermaCube™ Thermal Delivery System must be used in conjunction with CookTek® approved TCL bags and TCL FlashPak™ discs.

*of USA and imported parts

THERMACUBE™ DELIVERY SYSTEM INDUCTION CHARGER

TCS100

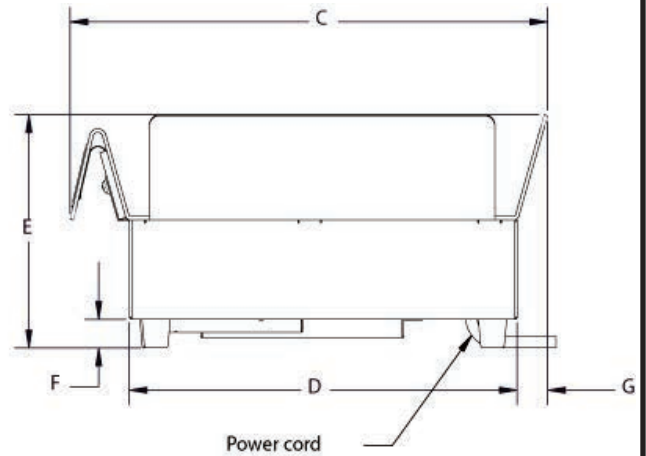
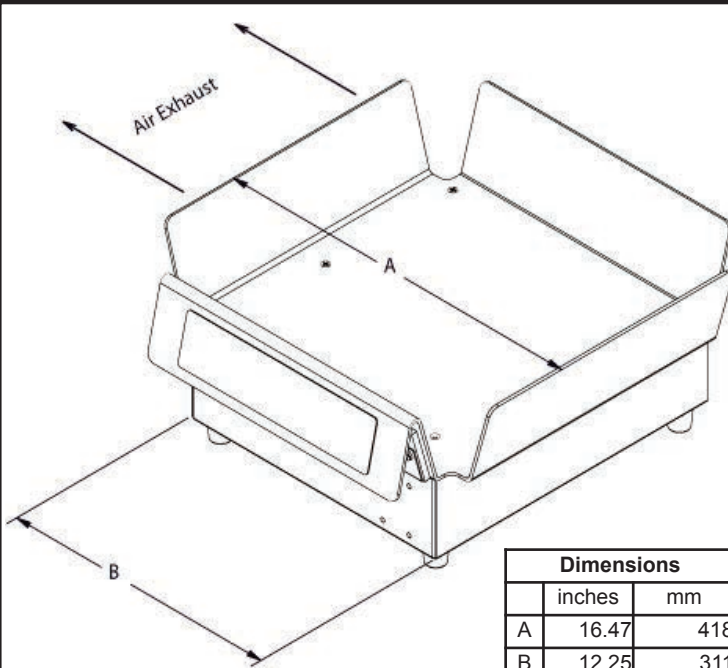

Dimensions		
	inches	mm
A	16.47	418
B	12.25	311
C	16.93	430
D	13.75	349
E	8.18	208
F	1.00	25
G	1.08	27



- Dedicated circuit required
- Requires maximum (do not exceed) ambient temperature of 50°C/122°F
- Cooling clearance: 2" (55mm) for front and rear, 6" (152mm) below when mounted in custom shelving unit

Specifications

Model Number	TCS100
Power Requirements	100-120VAC, 1Ph
Power Consumption	1800W
Voltage	100-120VAC, 50/60 Hz
Amperage	15A (max)
Base Dimensions (in)	13.75" x 12.25" x 4.25"
Base Dimensions (mm)	349 x 311 x 108
Dimensions w/bag locator (in)	16.47" x 16.93" x 8.18"
Dimensions w/bag locator (mm)	418 x 430 x 208
Weight	14.5 lbs / 6.6 kg
Packaged Weight	19.25 lbs / 8.7 kg
Packaged Dimensions (in)	23" x 20" x 13"
Packaged Dimensions (mm)	542 x 508 x 330
Power Cord Length	6 ft / 1.8 m
Plug Type	NEMA 5-15P
Warranty	36 month limited parts and labor (charger only)

Note: Ambient air should not exceed 50°C/122°F. Dedicated circuit required. Many local codes exist, and it is the Owner and Installer's responsibility to comply with those codes. CookTek continually improves its products and reserves the right to change or improve specifications without notice.

CookTek Induction Systems, LLC
156 N. Jefferson St. Ste 300
Chicago, IL 60661-1436, USA
www.cooktek.com

Tel: 1.312.563.9600 Fax: 1.312.432.6220
Toll Free: 1.888.COOKTEK (266.5835)
Toll Free Fax: 1.888.COOKFAX (266.5329)