

Sentry Series Mug



Improve your food service security in even the toughest, most abusive environments with the Sentry Series line of trays, tumblers, mugs and spork. This innovative meal servingware is made of FDA approved pliable material that bends so it's not a worthwhile material for inmates to make into a weapon. The line is highly durable long lasting, and the innovative material Poly-TPE-29 provides safety benefits that aren't available from Co-polymer or polycarbonate servingware

Sentry Series Mug

- **Innovative Material**

New FDA approved Poly-TPE-29 pliable plastic bends rather than breaks and won't shatter or crack

- **Enhanced Security**

Poly-TPE-29 bends so it is useless to inmates in fabricating weapons

- **Exceptional Value**

Enhance your food service security efforts with a minimal increase in investment over Co-polymer or Polycarbonate mugs

- **Easy-to-Clean**

Poly-TPE-29 pliable material is naturally stain resistant and will not retain odors or flavors from food

- **Warewasher Safe**

Withstands harsh chemicals and high temperatures making it safe for warewashing and the pliable material does not become brittle over time

- **Microwave Safe**

The Sentry series mug can be placed in a microwave and will not melt or lose shape, and will stay cool to the touch

- **Withstands Extreme Temperatures**

Temperature rating of -40°F to 248°F

- **Immediate Shipping**

In stock with same day shipping

- **Colors**

Mug is available in Tan or Brown

- **Capacity**

7 oz.

- **Package**

48 per case

- **Warranty**

2-Year Warranty against manufacturing defects

- **Model #'s**

630-360SST 7 oz. Tan Sentry Series Mug

630-360SSB 7 oz. Brown Sentry Series Mug

Project: _____
Item No: _____
Quantity: _____

27725 Diehl Road
Warrenville, IL 60555

Phone: 1-800-956-5571
Fax: 1-800-956-6822

Manufacturer: Cook's Brand
Product: Sentry Series Mug
630-360SST Tan 7 oz. Sentry Series Mug
630-360SSB Brown 7 oz. Sentry Series Mug
Dimensions: 2-1/2" Dia. x 3-7/16"H
Sizes: 7 oz.
Materials: Cook's Brand FDA approved material Poly-TPE-29
Shipping Class: 100
Information: NMFC (National Motor Freight Classification): 156600SUB06
(Shipping information by pallet available upon request, please call)
Shipping Weight: 24.5 lbs
Warranty: 2-year Warranty against manufacturing defects

Note: Specifications are subject to change without notice as necessitated by continuing product improvement.

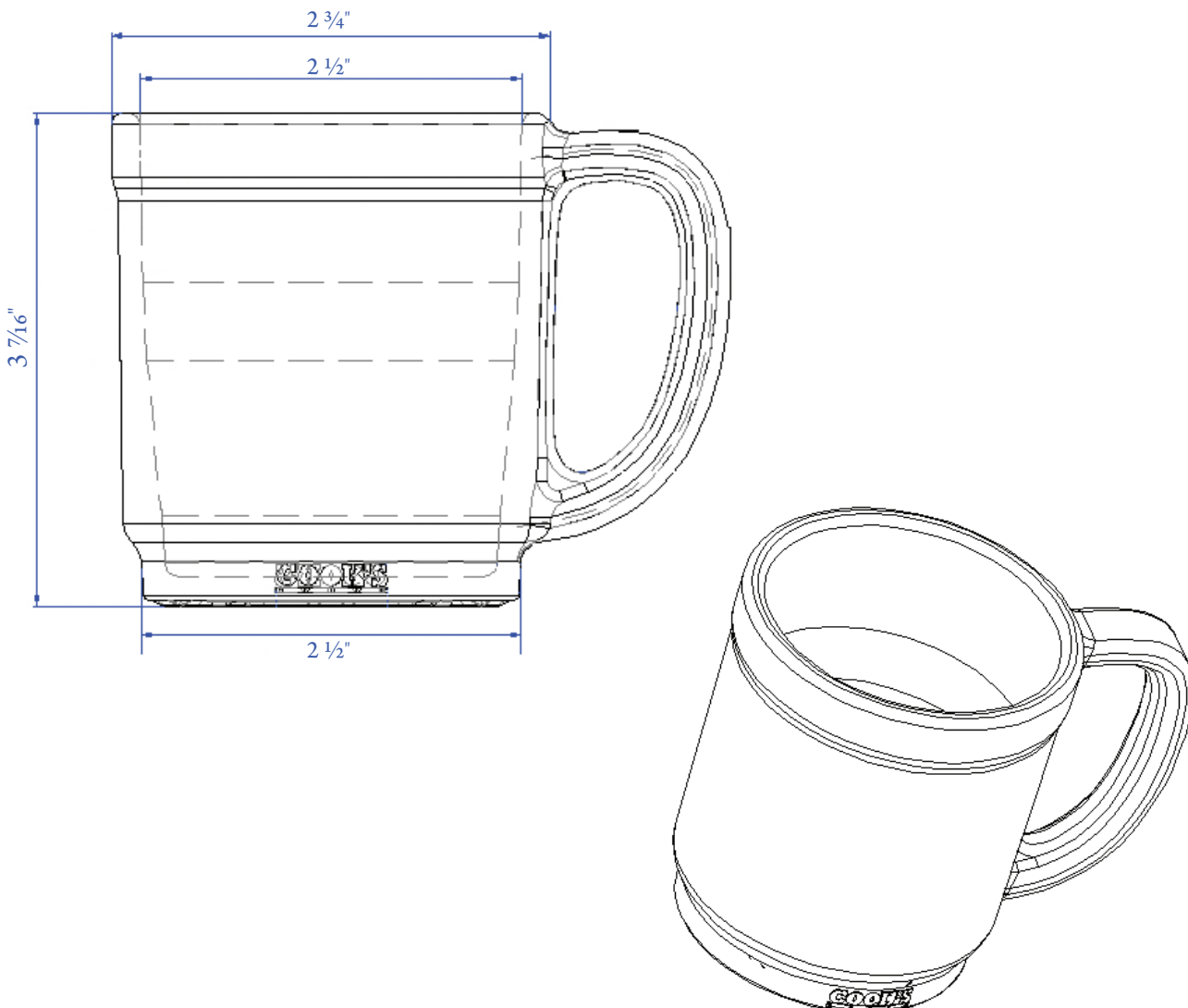

Sentry Series Mug