

## Grizzly Tray

## Grizzly Tray



You can count on the hot over hot, cold over cold design to keep meals at safe temperatures. Made from a specially blended stain resistant co-polymer, the Grizzly Tray is designed to look great for a long time and with the durable one-piece construction, they're built for a long life even in the toughest environment.

### • Rugged Construction

One-piece construction means no seams to split or crack

### • Exceptional Durability

Thick co-polymer skin with reinforced center bead and foam insulated interior add support and strength so that corners and sides are dent resistant

### • Maximum Heat Retention

Specialized insulation injection process eliminates air pockets to provide superior heat retention

### • Stain Resistant

Proprietary blend of co-polymer resists food stains for longer wearing appearance

### • No Holes

Trays will not absorb water extending the useful life of the tray

### • Reduced Spillage

Food compartments have raised lip reducing spills during transport

### • Heat Optimizing Layout

Designed to be stacked with hot food over hot food and cold food over cold food, the layout of this tray helps keep maintain food temperatures minimizing opportunities for food bourn illness

### • Tight Seal when Stacked

Two step design means top and bottom surfaces nest securely so trays will be flat and stack up straight improving heat retention of meals and food safety

### • Two Color Choices

Brown or Yellow

### • Immediate Shipping

In stock with same day shipping

### • Warranty

2-year "No Questions Asked" Full Replacement Warranty

### • Model #'s

630-110B Brown Tray  
630-110Y Yellow Tray

Project: \_\_\_\_\_  
 Item No: \_\_\_\_\_  
 Quantity: \_\_\_\_\_

27725 Diehl Road  
 Warrenville, IL 60555  
 Phone: 1-800-956-5571  
 Fax: 1-800-956-6822

## Grizzly Tray

**Manufacturer:** Cook's Brand  
**Product:** Grizzly Tray  
 630-110B Brown 4 Compartment Insulated Tray  
 630-110Y Yellow 4 Compartment Insulated Tray  
**Dimensions:** 14 1/2"L x 13"W x 2 3/8"D Tray  
**Compartment Sizes:** (2) 7 1/4"L x 5"W x 1"D  
 (2) 3 1/4"L x 4 1/2"W x 1"D  
**Materials:** Co-polymer plastic with foam insulation  
**Shipping Class:** 125  
**Information:** NMFC (National Motor Freight Classification): 156600SUB 05  
**Shipping Weight:** 25.55 lbs per case for trays  
 Call for pallet quantity estimate.  
**Warranty:** 2-year "No Questions Asked" Full Replacement Warranty

Note: Specifications are subject to change without notice as necessitated by continuing product improvement.

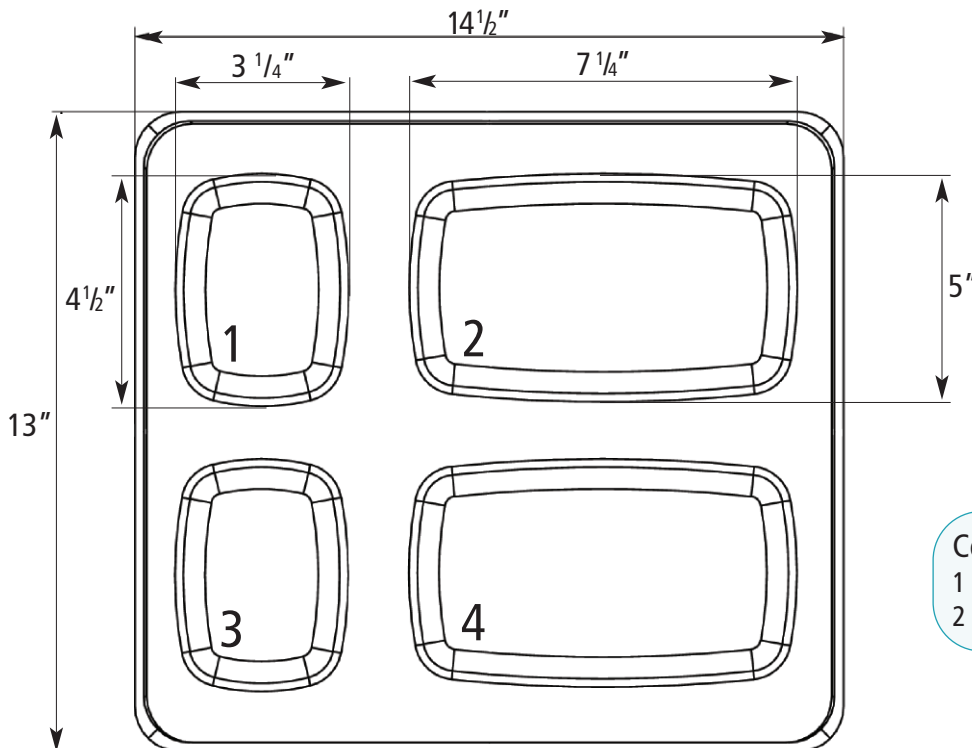
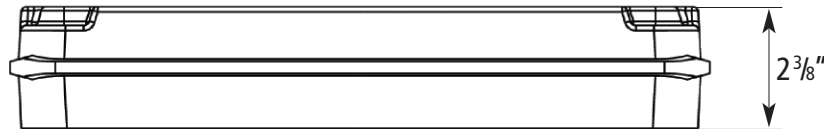

**Compartment Capacities**  
 1 & 3 - 6 oz side  
 2 & 4 - 12 to 16 oz entree/side