

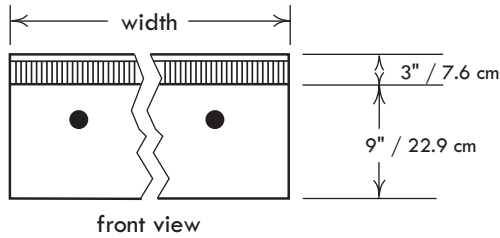

JOB _____ ITEM # _____

CHAR-BROILERS

E Series: 20" cook depth



Model ERB24

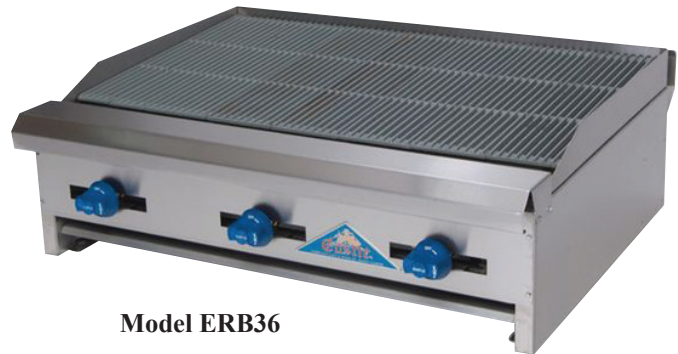
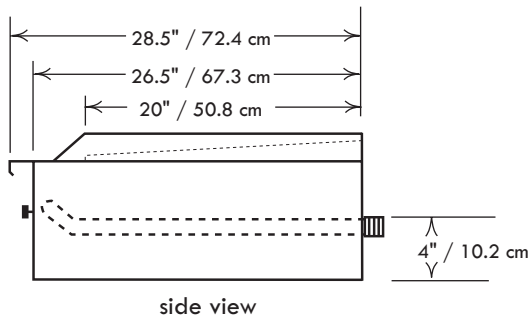

Model ERB36

Standard Features, Benefits & Options

CONSTRUCTION: Easy cleaning, stainless steel finish. 3" wide stainless steel bull nose landing across the front is a functional work area for service plates and work utensils as well as control protection. Heavy gauge welded frame construction. Installation clearances for non-combustible surfaces are 0" on the sides and 4" in the rear; combustible surfaces are 4" on the sides and 5" in the rear.

TOP GRATES: Cast iron top grate sections measure 20" deep, designed with cast-in grease trough on each blade to allow grease run off into the front cold zone grease trough and reduces flare up. Each section is reversible for sloped or level grilling. Stainless steel splash guards on 3 sides graduating up to 3" high. Grease drain slot is 3.5" x 1" and feeds into a large, removable grease drawer.

CONTROLS: Equipped with brass gas valves and automatic standing pilots. Pressure regulators are set at the factory for the gas specified. Optimal pressures are 4" WC for natural gas and 10" WC for propane. Manifold size is 3/4" NPT. All controls are tested and confirmed in good working order. Calibration and adjustments are the responsibility of the installer.

BURNERS: 12" incremental char-broilers feature 30,000 BTU burners, one for each 12" increment. 18", 30" and 42" models feature 2, 4 and 6 burners respectively, each rated at 18,000 BTU.

MATCH-UP: E Series char-broilers are designed to match up with E griddles.

ACCESSORIES & OPTIONS: Sturdy 2½" or 4" heavy duty legs with adjustable feet, safety pilot controls, gas hoses, grill scrapers, spatulas, cleaning supplies, carrying handles, knob protectors and matching equipment stands.

SPECIFICATIONS

Model Number	Width in./mm.	Sq. in. surface	Total BTU	Approx. kg/lbs
ELB12	12 / 305	240	30K	48 / 105
ERB12	12 / 305	240	30K	48 / 105
ELB18	18 / 457	360	36K	57 / 125
ERB18	18 / 457	360	36K	57 / 125
ELB24	24 / 610	480	60K	68 / 150
ERB24	24 / 610	480	60K	68 / 150
ELB30	30 / 762	600	72K	80 / 175
ERB30	30 / 762	600	72K	80 / 175
ELB36	36 / 914	720	90K	91 / 200
ERB36	36 / 914	720	90K	91 / 200
ELB42	42 / 1069	840	108K	107 / 235
ERB42	42 / 1069	840	108K	107 / 235
ELB48	48 / 1219	960	120K	125 / 275
ERB48	48 / 1219	960	120K	125 / 275
ELB60	60 / 1524	1200	150K	152 / 335
ERB60	60 / 1524	1200	150K	152 / 335
ELB72	72 / 1829	1440	180K	205 / 450
ERB72	72 / 1829	1530	180K	205 / 450

NOTICE: In an ongoing effort of product development & improvement, Comstock-Castle reserves the right to change specifications and product design without notice. Such modifications do not entitle the buyer to corresponding changes or replacements for previously purchased equipment.



Comstock-Castle Stove Co. • 119 W. Washington St. • Quincy, IL. 62301
 Tel.: 217-223-5070 • Fax: 217-223-0007 • www.castlestove.com

