



# ColdTech – Culinary Coolness

## Stainless Steel Single Door Commercial Refrigerator CRR229-1



### Highlights:

- Solid, durable, one door, high grade, 300 series, stainless steel interior & exterior (except backs) providing commercial kitchens with a long-lasting, easy to clean refrigerator.
- Digital temperature controls on the outside of the unit for easy programming. 1° C to 6° C/33° F to 43° F
- The **ColdTech Commercial** Warranty: 3 years bumper-to-bumper & a total of 5 years warranty on the compressor. Call **ColdTech Commercial** directly for repairs & service 24/7/365. It's the best warranty in commercial refrigeration.
- We make it easy. Recessed door handles for easy cleaning, bottom-mounted compressor for easy access, auto-defrost, & free standing with four, black casters for easy moving.
- Energy Star rated to help maximize your energy and dollar savings.
- Three movable, plastic coated, steel shelves holding up to 80 kg/176.4 lbs each and internal incandescent lighting.



### Features:

- Large gross capacity of 23 cu. ft./ 650L to get the maximum amount of refrigeration per cabinet size.
- Ventilated cooling system.
- North American standard safety & sanitation.
- Stainless steel drip tray under the evaporator.
- Net weight: 144 kg/317.5 lbs & Gross weight: 161 kg/354.9 lbs
- Efficient condenser and evaporator made from copper piping with aluminum fin for faster cooling and superior efficiency.
- Bottom mounted sealed systems for cooler operating environment allowing your compressor to work less to keep consistent cool.
- Housing and liner material are durable, food safety friendly, high quality, 300 series stainless steel .
- Temperature ranges from 1° C to 6° C/33° F to 43° F



Watch Our Videos Online:  
[ColdTechCommercial.com/Videos](http://ColdTechCommercial.com/Videos)

### Stainless Steel

Solid, Durable high grade, 300-series, interior and exterior

### Warranty

3 Years bumper to bumper & a total of 5 years warranty on the compressor

### Digital Display

Digital temperature controls on the outside of the unit for easy programming

[ColdTechCommercial.com](http://ColdTechCommercial.com)

Toll free: 1-855-241-3251 FAX: 1-877-298-8278

email: [info@coldtechcommercial.com](mailto:info@coldtechcommercial.com)



## Specifications:

Voltage: 115 volts/20 amp circuit

Amperage: 7.4 amps/338 W

Compressor Power: 418 W

Hp: 4/7 horsepower

dB: 65

Energy Consumption:  
2.24 kw.h/24 h

### Free Standing

Gross Capacity:  
23 cubic feet / 650 L

Refrigerant Type:  
CFC Free R134a

Blowing Agent:  
CFC Free polyurethane

Temperature Range:  
• 1° C to 6° C  
• 33° F to 43° F

Thermostat/Temperature Display:  
Digital

Doors: Self closing, recessed  
handles, 300 series stainless steel

Shelving: Plastic coated steel holds  
up to 80 kg/176.4 lbs

Interior lighting:  
1 incandescent yellow bulb

Casters: 4

Cord Length: 112 <sup>3</sup>/<sub>16</sub>"/2850 mm

Unit Dimensions (W x H x D):  
736 mm x 2095 mm x 818 mm  
29" x 82 1/2" x 32 <sup>3</sup>/<sub>16</sub>"

Carton Dimensions (W x H x D):  
800 mm x 2140 mm x 880 mm  
31 1/2" x 84 1/4" x 34 5/8"

Shipping Cube:  
54.03 cu.ft/1.53cbm

Net Weight: 144 kg /317.5 lbs

Gross Weight: 161 kg /354.9 lbs

## Stainless Steel Single Door Commercial Refrigerator CRR229-1

### Elevation:

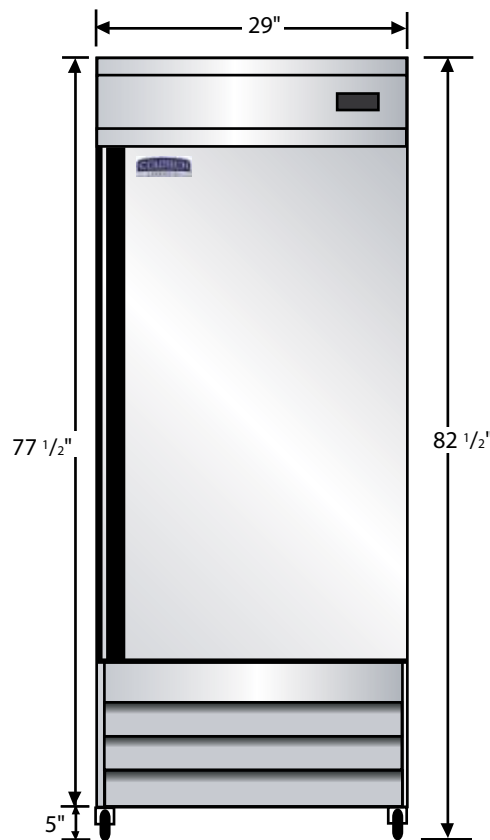

### Top View:

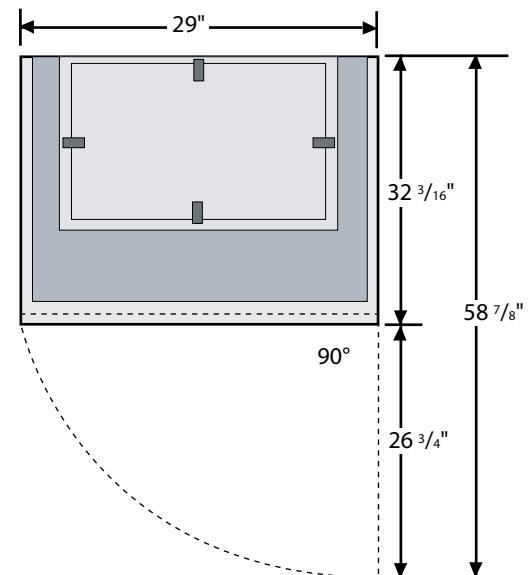

### Notes:



### Plug:



### Certifications:



Specifications subject to change without notice. 031512

ColdTechCommercial.com

Toll free: 1-855-241-3251 FAX: 1-877-298-8278

email: info@coldtechcommercial.com

