



Item # _____

Model CC34 Combination Food Processor



Model CC34



Features

Berkel Model CC34 combination food processor is a high-performance and versatile machine that quickly and conveniently chops, slices, dices, blends and mixes vegetables, fruits, cheese and virtually any other product. Constructed of heavy-duty aluminum with integrated handles, the compact CC34 is easy to move from one location to another. Stainless steel bowl provides superior durability and long life. The continuous feed attachment includes an automatic start/stop function, feed tube and design that allows the operator to load product with both hands for the fastest possible processing. The exclusive SureSense™ speed setting automatically senses whether the feed head or bowl is attached for perfect processing results. The dual interlock boosts operator protection. The CC34 has a variety of cutting plates to optimize the versatility and productivity of this superior machine.

Standard Features

- Slices, dices, shreds, grates and juliennes fruit, vegetables, dry bread, cheese, nuts, etc.
- Chops and grinds meat, fish, fruit, vegetables and nuts.
- Blends and mixes sauces, aromatic butter, mayonnaise, soups, dressing, thickenings, desserts, etc.
- Prepares up to 4.4 lbs (2 kg) per minute with the continuous feed attachment.
- 4-speed, 1-1/2 HP, thermal motor protection with automatic reset.
- Furnished in 120/60/1, UL listed.
- The exclusive SureSense™ speed setting ensures optimal speed settings and perfect cutting results for the required applications.
- Pulse function for precise operator control.
- Continuous feed attachment includes feed head and ejector plate.
- Furnished with 5/64" (2 mm) shredder plate and 5/32" (4 mm) slicing plate.
- Cutter/Mixer attachment includes 3.2 Quart (3 liter) stainless steel bowl, knife unit, lid and scraper.
- Cutter/Mixer knife unit with serrated blades for faster processing.
- Bowl scraper for uniform mixing that is removable for easy cleaning.
- Aluminum machine base and stainless steel bowl for increased durability.

Options

- Unit without slicing and shredding plates.

Accessories

- Slicing Plates – 1/32" (1 mm), 5/64" (2 mm), 5/32" (4 mm), 1/4" (6 mm) and 3/8" (10 mm)
- Crimping Plate – 3/16" (4.5 mm)
- Shredder Plates – 5/64" (2 mm), 3/16" (4.5 mm), 1/4" (6 mm) and 5/16" (8 mm)
- Fine Grater Plate
- Julienne Plate – 5/64 x 5/64" (2x2 mm) and 3/16 x 3/16" (4.5x4.5mm)
- Dicing Grid – 3/8" x 3/8" (10x10 mm) and 5/8" x 5/8" (15x15 mm)
- Replacement Blades - Slicing and Crimping
- Wall Rack

Approved By: _____ Date _____
--

**Berkel Company • 4406 Technology Drive • South Bend, IN 46628-9700
574-232-8222 • 800-348-0251 • FAX 888-888-2838 • www.berkel.com**

Berkel

Model No.	Capacity		Product Dimensions			Weight
			Width A	Depth B	Height C	
CC34	Cont. Feed - 4.4 lbs./min. (2 kg/min.)	Cont. Feed	11" (280 mm)	13-3/4" (350 mm)	23" (585 mm)	Net 23 lbs. (11 kg) Ship 33 lbs. (15 kg)
	Bowl - 3.2 quarts (3 liters)	Bowl	11" (280 mm)	13" (330 mm)	17" (432 mm)	

Motor	Electrical	Cutting Speeds	Box Dimensions		
			Width A	Depth B	Height C
1-1/2 HP	120/60/1 9 amps	Cont. Feed - 500/800 rpm Bowl - 1,450/2,650 rpm	16-1/4" (413 mm)	16-1/4" (413 mm)	27" (686 mm)

Specifications

Motor: 1-1/2 hp, 4-speed, thermal motor protection with automatic reset.

Electrical: Furnished in 120/60/1, 9 amps, UL Listed, 3-wire electrical cord and plug. Cord is 6' in length.

Finish/Construction: Machine base of aluminum. Cutter/Mixer attachment bowl of stainless steel, lid and scraper of polycarbonate. Continuous feed attachment and ejector plate of polycarbonate. Cutting plates and knife hub of polycarbonate and aluminum. All blades of stainless steel.

Controls: Sealed dial controls with integrated pulse function.

Speeds: 4 speeds with SureSense™ automatic speed settings: 2 high speeds (1,450/2,650 rpm) for chopping and blending, 2 low speeds (500/800 rpm) for slicing, dicing, shredding and grating.

Operator Protection: Dual interlocks keeps machine from operating unless attachments are in the proper position.

Capacity: 3.2 quart stainless steel cutter/mixer bowl. 4.4 lbs./minute with continuous feed attachment.

Warranty: Parts, labor and travel coverage for one year, exclusive of wear items.

As we continually strive to improve our products, specifications are necessarily subject to change without notice.

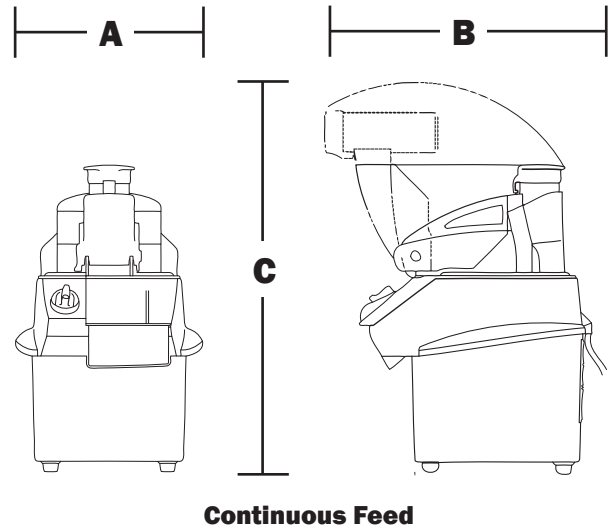

Continuous Feed

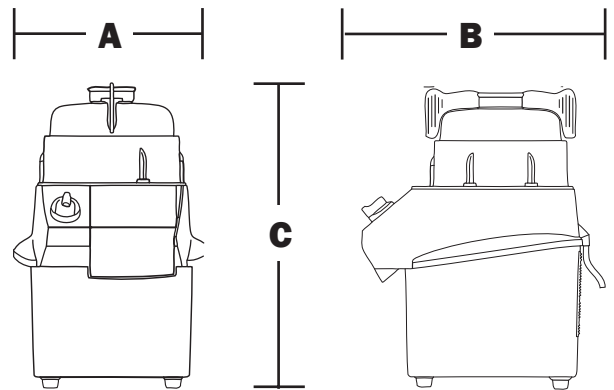

Cutter/Mixer (Bowl)

**Berkel Company • 4406 Technology Drive • South Bend, IN 46628-9700
574-232-8222 • 800-348-0251 • FAX 888-888-2838 • www.berkel.com**