

7•14esi SERIES COMBITHERM® COMBIOVEN



- EcoSmart design uses less electricity and water than competitive models. Reduced energy setting further minimizes electricity use.
- Exclusive Gold-n-Brown™ features gives the operator the ability to achieve the ideal cooking environment for the ideal finish.

- Expandable system to meet your specific requirements.
- Cook with the included product temperature probe (not included as standard on S-control models) or by time.
- Cooks with variable steam, convection heat, or a combination of both to roast, steam, bake, or oven-fry. Cooking speeds are increased by as much as 70% compared to conventional cooking methods.
- CombiClean® feature uses jets of water for fully automated cleaning. Use either commercial-strength CombiClean Tablets or Combitherm Cleaning Liquid Spray.
- Boiler-free flash-steam generation increases reliability by eliminating boiler maintenance and boiler heating element burnout. Steam levels are maintained without a water reservoir.
- Optional, CombiSmoker® oven with smoking technology smokes any product, hot or cold.
- **CombiTouch®**
 - Intuitive CombiTouch control is fully operable from the touch screen.
 - Store up to 250 recipes, each with up to 9 steps. CombiTouch comes standard with more than 100 preprogrammed recipes and photos.
 - Six precise and consistent Gold-n-Brown™ browning levels.
 - Multi-shelf Timers track cooking time of seven different food items in the same oven.
 - Advanced reversing fan design provides excellent baking results and prevents excessive water and power consumption.

MODEL 7•14esi WITH COMBITOUCH CONTROL
CAPACITY OF FOURTEEN (14) FULL-SIZE OR GN 1/1 PANS,
SEVEN (7) FULL-SIZE SHEET OR GN 2/1 PANS



Provide Alto-Shaam Combitherm® counter-top Model 7•14esi flash-steam electric CombiOven designed with EcoSmart® technology for reduced energy and water usage and include operational modes for steam, convection, and a combination of steam and convection heat. Standard features to include patented automatic steam venting; Gold-n-Brown™ browning function and a self-adjusting, flush-mounted rotary door handle. Oven is to be constructed of 18 gauge stainless steel, include an attached spray hose with backflow preventer, cool-down function, automatic cleaning function, and four (4) adjustable legs. Each oven is to accommodate up to 7 full-size sheet pans or 14 full-size hotel pans, include standard right-hand door hinging, seven (7) non-tilt support rails (21-1/16" (535mm) horizontal width between rails, and 2-5/8" (65mm) vertical spacing between rails), and four (4) stainless steel shelves.

- CombiTouch® Control:** includes six different browning levels; two-speed reversing fan with coordinated venting system, USB port for data access, quick-connect single-point internal product temperature probe in the oven interior.

- Deluxe Control:** includes a quick-connect single-point internal product temperature probe in the oven interior and programming capability with Rapid-Touch™ operational quick-keys.

- Standard Control:** includes a quick-connect single-point internal product temperature probe in the oven interior.

- S-Control:** with quick-connect single-point internal product temperature probe in the oven interior as an option.

FACTORY INSTALLED

- Electrical Choices
 - Specify voltage:
 - 208-240 1ph
 - 208-240 3ph
 - 380-415 3ph
 - 440-480 3ph
 - Smoking Function, optional
 - CombiHood® VHes-10, (not available on smoker models, left hand door hinging, or stacked combinations)
- Door Swing
 - Specify choice
 - Right-hand Door Hinging, standard
 - Left-hand Door, optional increases oven width by 1" (25mm)
 - Recessed Door, optional increases oven width by 4" (102mm)
 - Grease Collection System [5008038], mobile collection tank on casters with dedicated oven grease drain line. Optional oven stand is required with this system.
- Probe
 - Specify choice
 - Multi-point, hard-wired temperature probe [5005678] - not available on ovens with S-Control
 - Single-point, removable temperature probe - included on Touch, Deluxe and Standard controls
 - S-Control oven without smoker [5005679]
 - S-Control oven with smoker [5011457]
- Security Devices for correctional facility use.
 - Base package: excludes temperature probe
 - Specify additional choices
 - Anti Entrapment Device [5011081]
 - Control Panel Security Cover [5012224]
 - Hasp Door Lock (padlock not included) [5011680]
 - Tamper-Proof Screw Package for oven [5013924]
 - Seismic Feet Package [5011135]



7•14ESi SERIES COMBITHERM[®] COMBIOVEN

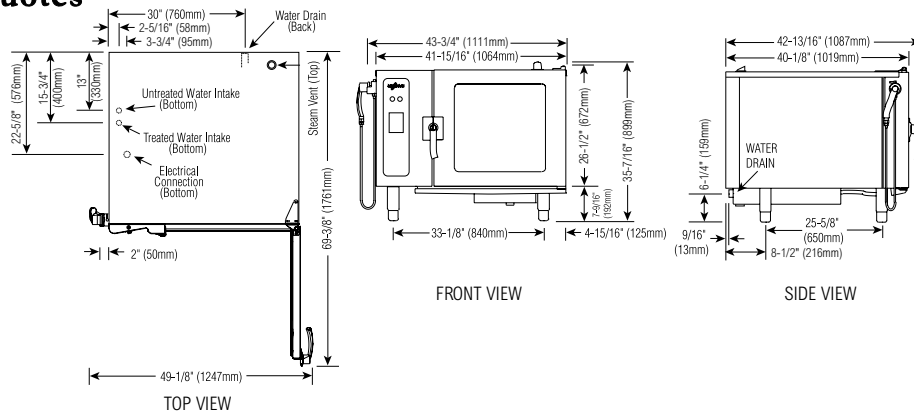

STACKING COMBINATION DIMENSIONS: H x W x D	DIMENSIONS: H x W x D																
<input type="checkbox"/> 6.10es over 7.14es 67" x 43-7/8" x 42-15/16" (1701 x 1114 x 1090mm)	EXTERIOR: 34-1/4" x 43-7/8" x 42-13/16" (869mm x 1114mm x 1087mm)																
<input type="checkbox"/> 7.14es over 7.14es 67" x 43-7/8" x 45-1/4" (1701 x 1114 x 1150mm)	EXTERIOR WITH RECESSED DOOR: 34-1/4" x 47-7/8" x 42-13/16" (869mm x 1216mm x 1087mm)																
<input type="checkbox"/> 7.14es over ASC-4E 73-5/8" x 41-7/8" x 46-9/16" (1869 x 1064 x 1182mm)	INTERIOR: 20-5/16" x 23-1/2" x 28-7/8" (515mm x 596mm x 722mm)																
<input type="checkbox"/> Mobile option with 5" (127mm) casters will add 2" (51mm) to the overall height.																	
WATER REQUIREMENTS	WATER QUALITY MINIMUM STANDARDS																
<p>TWO (2) COLD WATER INLETS - DRINKING QUALITY</p> <p>ONE (1) TREATED WATER INLET: 3/4" NPT* * Can manifold off of one 3/4" line.</p> <p>ONE (1) UNTREATED WATER INLET: 3/4" NPT*</p> <p>LINE PRESSURE: 30 to 90 psi 2.8 to 6.2 bar</p> <p>WATER DRAIN: 1-1/2" CONNECTION WITH A 2" MINIMUM AIR GAP INSTALLED AS CLOSE TO THE OVEN AS POSSIBLE</p>	<p>USING A WATER SUPPLY NOT MEETING ALTO-SHAAM'S MINIMUM WATER QUALITY STANDARDS WILL VOID THIS WARRANTY. It is the responsibility of the purchaser to ensure that incoming water supply is compliant with the specifications listed through adequate treatment measures. Installation of the CombiGuard™ Water Filtration System is recommended, but this system may not address all water quality issues present.</p>																
CLEARANCE REQUIREMENTS																	
<p>LEFT 6" (152mm) RECOMMENDED SERVICE ACCESS: 18" (457mm) 20" (508mm) FROM HEAT PRODUCING EQUIPMENT</p> <p>RIGHT 4" (102mm) TOP: 20" (508mm) FOR AIR MOVEMENT</p> <p>BACK 4" (102mm) BOTTOM: 5-1/8" (130mm) FOR LEGS</p>	<table border="0"> <tr> <td>Contaminant</td> <td>Inlet Water Requirements (untreated water)</td> </tr> <tr> <td>Free Chlorine</td> <td>Less than 0.1 ppm (mg/L)</td> </tr> <tr> <td>Hardness</td> <td>Less than 3 gpg (52 ppm)</td> </tr> <tr> <td>Chloride</td> <td>Less than 30 ppm (mg/L)</td> </tr> <tr> <td>pH</td> <td>7.0 to 8.5</td> </tr> <tr> <td>Alkalinity</td> <td>Less than 50 ppm (mg/L)</td> </tr> <tr> <td>Silica</td> <td>Less than 12 ppm (mg/L)</td> </tr> <tr> <td>Total Dissolved Solids (tds)</td> <td>Less than 60 ppm</td> </tr> </table>	Contaminant	Inlet Water Requirements (untreated water)	Free Chlorine	Less than 0.1 ppm (mg/L)	Hardness	Less than 3 gpg (52 ppm)	Chloride	Less than 30 ppm (mg/L)	pH	7.0 to 8.5	Alkalinity	Less than 50 ppm (mg/L)	Silica	Less than 12 ppm (mg/L)	Total Dissolved Solids (tds)	Less than 60 ppm
Contaminant	Inlet Water Requirements (untreated water)																
Free Chlorine	Less than 0.1 ppm (mg/L)																
Hardness	Less than 3 gpg (52 ppm)																
Chloride	Less than 30 ppm (mg/L)																
pH	7.0 to 8.5																
Alkalinity	Less than 50 ppm (mg/L)																
Silica	Less than 12 ppm (mg/L)																
Total Dissolved Solids (tds)	Less than 60 ppm																

INSTALLATION REQUIREMENTS
<ul style="list-style-type: none"> Oven must be installed level. Hood installation is required. Water supply shut-off valve and back-flow preventer when required by local code.

ELECTRICAL (DEDICATED CIRCUIT REQUIRED)								CombiSmoker®
MODEL	VOLTAGE	PH	HZ	AMPS	kW	AWG	CORD & PLUG	Additional kW
7•14ESi Touch	208 – 240	1*	60	70.0 - 79.2	14.5 - 19.0	AWG 3	no cord or plug	+ .7 kw
	208 – 240	3	60	40.3 - 46.0/ph	14.5 - 19.0	AWG 6	no cord or plug	+ .7 kw
	380 – 415	3	50	22.0 - 26.3/ph	14.4 - 18.9	AWG 10	no cord or plug	+ .7 kw
	440 – 480	3*	60	19.0 - 22.8/ph	14.4 - 19.0	AWG 8	no cord or plug	+ .7 kw
7•14ESi	208 – 240	1*	60	69.2 - 79.0	14.4 - 18.9	AWG 3	no cord or plug	+ .7 kw
	208 – 240	3	60	40.0 - 45.5/ph	14.4 - 18.9	AWG 6	no cord or plug	+ .7 kw
	380 – 415	3	50	22.0 - 26.3/ph	14.4 - 18.9	AWG 10	no cord or plug	+ .7 kw
	440 – 480	3*	60	21.0 - 23.0/ph	15.9 - 18.9	AWG 8	no cord or plug	+ .7 kw

*ELECTRICAL SERVICE CHARGE APPLIES

WEIGHT		CAPACITY		
NET	405 lb (184 kg)	FULL-SIZE PANS:	20" x 12" x 2-1/2"	Fourteen (14)
SHIP	540 lb (245 kg)	GN 1/1:	530 x 325 x 65mm	Fourteen (14)
CRATE DIMENSIONS: (L x W x H) 53" x 45" x 49" (1346 x 1143 x 1245mm)		GN 2/1:	650 x 530 x 65mm	Seven (7)
		FULL-SIZE SHEET PANS:* ON WIRE SHELVES ONLY	18" x 26" x 1"	Seven (7)
168 lb (76 kg) MAXIMUM				
VOLUME MAXIMUM: 105 quarts (133 liters)				

*ADDITIONAL WIRE SHELVES REQUIRED FOR MAXIMUM CAPACITY

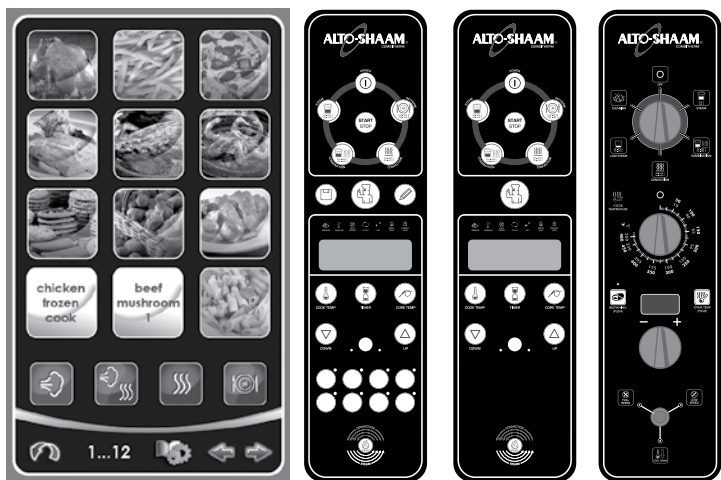

CombiTouch

Deluxe

Standard

S-Control

7-14ESi SERIES

COMBITHERM® COMBIOVEN



Steam Mode

- Automatic steaming at 212°F (100°C).
- Quick steaming.
 - Touch — 213°F to 250°F (101°C to 121°C).
 - Deluxe, Standard, S-Control — 213°F to 248°F (101°C to 120°C).
- Low temperature steaming for poaching or proofing.
 - Touch — 85°F and 211°F (29°C and 99°C).
 - Deluxe, Standard, S-Control — 86°F and 211°F (30°C and 99°C).



Combination Mode

- Combines steam and convection modes for faster production and better moisture retention.
- Improves yield, quality and shelf life.
- Automatic humidity control.
 - Touch — 212°F to 485°F (100°C to 252°C).
 - Deluxe, Standard, S-Control — 212°F to 482°F (100°C to 250°C).



Convection Mode

- Cooking, roasting, baking and finishing applications.
 - Touch — 85°F to 485°F (29°C to 252°C).
 - Deluxe, Standard, S-Control — 86°F to 482°F (30°C to 250°C).



Retherm Mode

- Bulk food or plated meal reheating with automatic steam injection.
 - Touch — 245°F to 320°F (118°C to 160°C).
 - Deluxe, Standard, S-Control — 248°F to 320°F (120°C to 160°C).
- Automatic humidity control.



Gold-n-Brown™

- Gold-n-Brown vents just the right amount of humidity in the oven cavity for perfect browning.
 - Touch — Six levels of Gold-n-Brown are featured.



Moisture Injection

- A quick burst of moisture can be added with a touch of a button at any time when cooking in the convection mode.



HACCP Data Access (CombiTouch only)

- Records cooking mode, time and temperature completed within a two week time period. The information is captured in a text format and can be downloaded to a USB device.



CombiSmoker® (option)

- Smoke any product, hot or cold, utilizing real wood chips.
- Functions in both combination and convection mode.
- Function can be programmed into operating procedure.
- Sample bag of wood chips included.

OPTIONS & ACCESSORIES		
<input type="checkbox"/>	CHICKEN GREASE TRAY WITH DRAIN: 1-1/2" (38mm) DEEP	4758
<input type="checkbox"/>	CHICKEN GREASE TRAY WITH DRAIN: 2-3/4" (70mm) DEEP	14475
CHICKEN ROASTING RACKS:		
<input type="checkbox"/>	6 CHICKEN CAPACITY — FITS FULL-SIZE PAN: 4 RACKS PER OVEN	SH-23000
<input type="checkbox"/>	8 CHICKEN CAPACITY — FITS FULL-SIZE PAN: 4 RACKS PER OVEN	SH-23619
<input type="checkbox"/>	10 CHICKEN CAPACITY — FITS IN SIDE RACKS: 4 RACKS PER OVEN	SH-22634
<input type="checkbox"/>	COMBIGUARD™ BWS BLENDED WATER SYSTEM (INCLUDES 50 GALLON TANK, 1 MEMBRANE & 3 FILTERS)	FI-28727
<input type="checkbox"/>	COMBIGUARD™ BWS REPLACEMENT FILTER CARTRIDGE AMS-QT	FI-29316
<input type="checkbox"/>	COMBIGUARD™ BWS REPLACEMENT FILTER CARTRIDGE SCLX2-Q	FI-29317
<input type="checkbox"/>	COMBIGUARD™ BWS REPLACEMENT PREFILTER FILTER CARTRIDGE CTO-Q	FI-29318
<input type="checkbox"/>	COMBIGUARD™ 10 TRIPLE-GUARD WATER FILTRATION SYSTEM (INCLUDES 1 CARTRIDGE)	FI-23014
<input type="checkbox"/>	COMBIGUARD™ 10 TRIPLE-GUARD REPLACEMENT FILTER	FI-26356
<input type="checkbox"/>	COMBIGUARD™ 20 TRIPLE-GUARD WATER FILTRATION SYSTEM (FOR STACKED UNITS, INCLUDES 1 CARTRIDGE)	FI-28728
<input type="checkbox"/>	COMBIGUARD™ 20 TRIPLE-GUARD REPLACEMENT FILTER (FOR STACKED UNITS)	FI-28744
<input type="checkbox"/>	COMBITHERM CLEANING LIQUID — SPECIALLY FORMULATED FOR COMBITHERM OVENS	
	➔ TWELVE (12) CONTAINERS/CASE, 1 QUART (C. 1 LITER) EACH [SPECIAL HANDLING REQUIRED]	CE-24750
<input type="checkbox"/>	COMBICLEAN® TABLETS — SPECIALLY FORMULATED FOR COMBITHERM OVENS	
	➔ 90 PACKETS EACH CONTAINER	CE-28892
<input type="checkbox"/>	EXTENDED ONE-YEAR WARRANTY	CONTACT FACTORY
<input type="checkbox"/>	FRY BASKET, 12" x 20" (325mm x 530mm)	BS-26730
<input type="checkbox"/>	GRILLING GRATE, 12" x 20" (325mm x 530mm)	SH-26731
<input type="checkbox"/>	PROBE, SOUS VIDE	PR-34747
<input type="checkbox"/>	SCALE FREE™ (CITRUS BASED, NON-CORROSIVE DELIMING PRODUCT)	CE-27889
<input type="checkbox"/>	SERVICE START-UP CHECK AVAILABLE THROUGH AN ALTO-SHAAM FASTEAM CENTER	SPECIFY AS REQUIRED
<input type="checkbox"/>	SHELF, STAINLESS STEEL WIRE	SH-22584
STAND, STAINLESS STEEL (H X W X D):		
<input type="checkbox"/>	➔ STATIONARY WITH SHELF 29-7/16" x 35-7/16" x 28" (746mm x 900mm x 710mm)	5005731
<input type="checkbox"/>	➔ STATIONARY WITH PAN SLIDES & SHELF 29-7/16" x 35-7/16" x 28" (746mm x 900mm x 710mm)	5005732
<input type="checkbox"/>	➔ MOBILE WITH SHELF 32-1/16" x 35-7/16" x 28" (815mm x 900mm x 710mm)	5005735
<input type="checkbox"/>	➔ MOBILE WITH PAN SLIDES & SHELF 32-1/16" x 35-7/16" x 28" (815mm x 900mm x 710mm)	5005736
<input type="checkbox"/>	➔ STATIONARY 37-3/4" x 35-7/16" x 28" (957mm x 900mm x 710mm)	5006170
WOOD CHIPS — BULK PACK 20 lb (9 kg)		
<input type="checkbox"/>	➔ Apple..... WC-22543	
<input type="checkbox"/>	➔ Cherry..... WC-22541	
<input type="checkbox"/>	➔ Hickory..... WC-2829	
<input type="checkbox"/>	➔ Maple..... WC-22545	